

INDUSTRIAL LINEAR PART NUMBER MATRIX

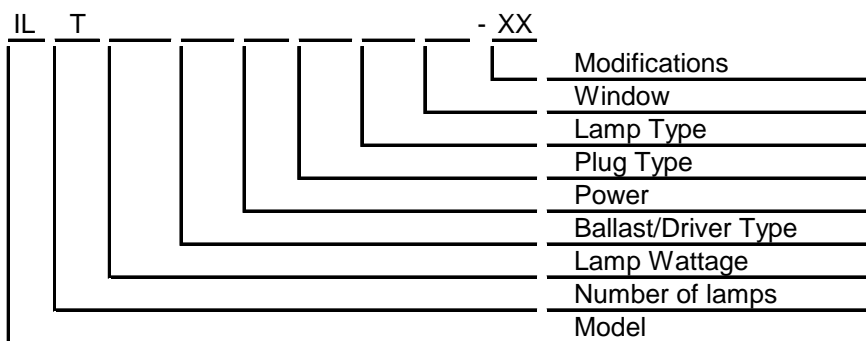

Model:	IL	Industrial Linear		
Number of lamps:	T	Twin Lamps (2x T5 lamps)		
Lamp Wattage:	04	4 Watt	06 6 Watt	26 26 Watt
	08	8 Watt	13 13 Watt	35 35 Watt
Ballast/Driver:	P	Plug-in, 25kHz (power option 1 only)		
	D	Direct/In-Line, 25kHz (Power 1 or 2 only) (26 & 35 Watt options are supplied w/ an In-Line, dual 25kHz ballast)		
	S	In-Line Ballast 85 kHz (Power Option 3)		
Plug/Cord Set:	1	110 VAC; 60Hz		
	2	220 VAC; 50Hz		
	3	85kHz w/ fixed intensity (90-260 VAC) (consult KSE "S" options with 26 or 35 options)		
Plug/Cord Set:	B	Euro/Shuko	C	Australia
	D	United Kingdom	E	Denmark
	F	France/Belgium	G	India
	H	Israel	I	Italy
	K	North American	L	Switzerland
	S	Special	X	No Plug
Lamp Type:	DD	Deluxe Dayligh, 5100K (std)	GR	Green (544nm)
	CW	Cool White, 4200K	BL	Blue (450nm)
	RD	Red (658nm)	BB	UV (365nm)
	YL	Yellow (585nm)		(BB requires Window option Q)
Window:	C	Clear (high output)		
	D	Diffuse (standard)		
	Q	UV Window (reqd for UV apps, lamp type BB)		
	T	50/50 (Blacklight applications)		
Modifications:		To be Determined		

